

DIE CHART

TO BE COMPLETED & SENT WITH DIE ORDER

CUSTOMER ADDRESS

Customer Authorisation
Customers Order Reference

Position
Account No.

Optional Safety Frame / False Table Supplied at Cost. If Not Required Please Sign Here :-

Die Equipment For Which Machine?

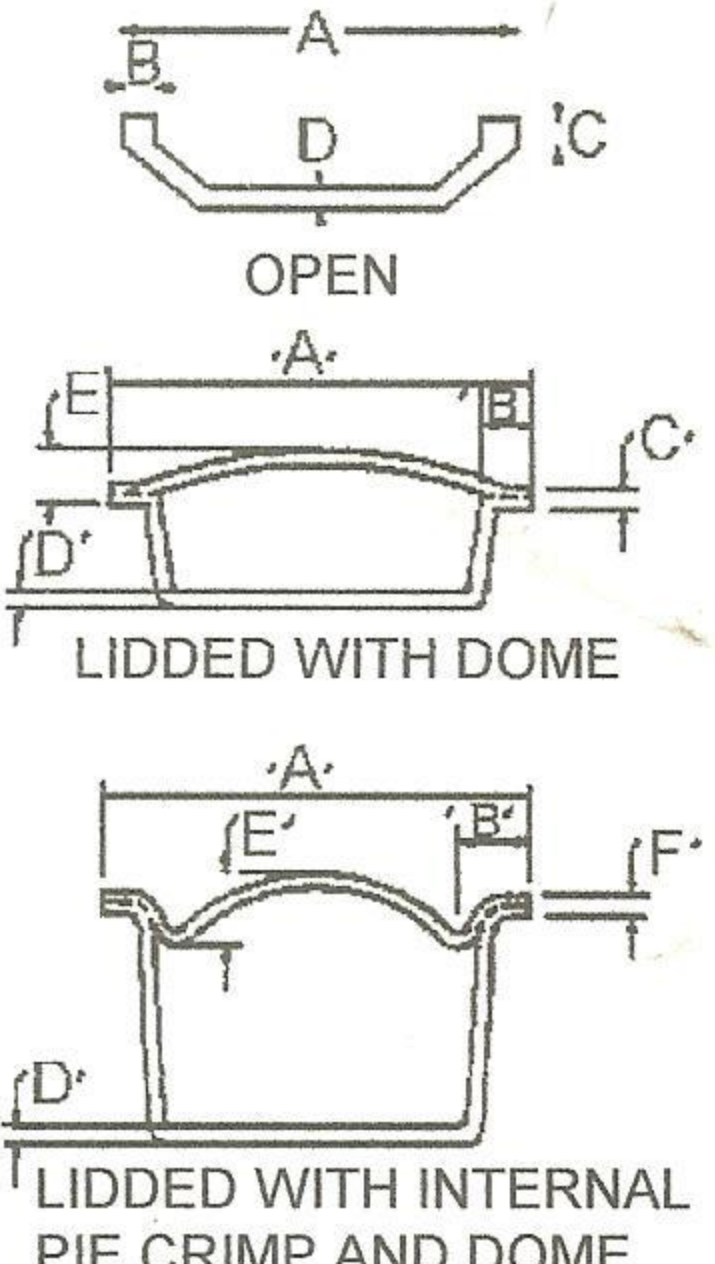
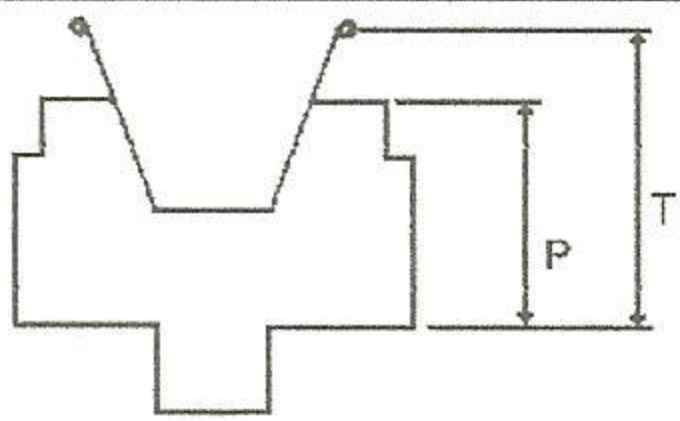
| PRODUCT PROFILE | DETAILS | all measurements in millimetres | |
|---|---|---------------------------------|-------------|
| | | BLOCKING DIE | LIDDING DIE |
|  <p>OPEN</p> <p>LIDDED WITH DOME</p> <p>LIDDED WITH INTERNAL PIE CRIMP AND DOME</p> | Foil No. | | |
| | TIN or HOOP No. | | |
| | CRIMP STYLE | | |
| | DIE TO CUT OFF (state YES or NO) | | |
| | CUT OFF DIAMETER 'A' | | |
| | CRIMP WIDTH | | |
| | CRIMP HEIGHT 'C' | | |
| | PASTE THICKNESS 'D' with 1 thick platform washer = 1.1/2mm | | |
| | DOMES HEIGHT 'E' | | |
| | DEPTH OF CRIMP 'F' (when below edge of tin) | | |
| NUMBER OF DOCKING PINS | | | |
| NUMBER OR AIR VENT PINS | | | |
| PLATFORM PROFILE | | PLATFORMS | |
|  <p>Dimensions 'P' and 'T' are necessary only where a moulding or lidding die is ordered for use with existing platforms or additional platforms are required.</p> | | | |
| | | | |
| | | | |
| | | | |
| | | | |

BASIC CRIMP STYLES



Custard



Pie



Plain



Rope



Raw Edge



Marguerite

Please fill in and send back thanks.